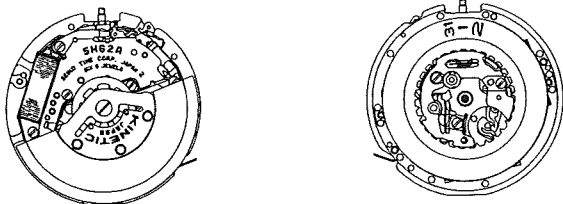

# PARTS CATALOGUE/TECHNICAL GUIDE

## Cal. 5M62A, 5M63A

### [SPECIFICATIONS]

Item		Cal. No.	5M62A, 5M63A
Movement			 <p>The illustrations refer to Cal. 5M62A. (x 1.0)</p>
Movement size	Outside diameter		ø27.6 mm
	Casing diameter		ø27.0 mm
	Height		4.3 mm
Time indication			3 hands
Driving system			Step motor (Load compensated driving pulse type)
Additional mechanism			<ul style="list-style-type: none"> <li>• Automatic generating system</li> <li>• Power reserve indicator</li> <li>• Energy depletion forewarning function</li> <li>• Overcharge prevention function</li> <li>• Electronic circuit reset switch</li> <li>• Train wheel setting device</li> <li>• Date calendar</li> <li>• Instant setting device for date calendar</li> <li>• Day calendar (for Cal. 5M63A only)</li> <li>• Instant setting device for day calendar (for Cal. 5M63A only)</li> </ul>
Loss/gain			Monthly rate at normal temperature range: less than 15 seconds
Regulation system			Nil
Measuring gate by quartz tester			Use 10-second gate.
Power supply	Power generator		Automatic generating system
	KINETIC E.S.U.		Titanium lithium ion rechargeable battery
Operating voltage range			0.45 V ~ 2.2 V
Duration of charge			From full charge to stoppage: Approx. 6 months
Jewels			6 jewels

# PARTS CATALOGUE

Cal. 5M62A, 5M63A

Disassembling procedures Figs. : ① → ⑥①  
 Reassembling procedures Figs. : ⑥① → ①

**Lubricating: Types of oil**

- Moebius A
- ▨ Moebius F
- SEIKO Watch Oil S-6
- Silicone oil 500,000 c.s.

**Oil quantity**

○ Normal quantity

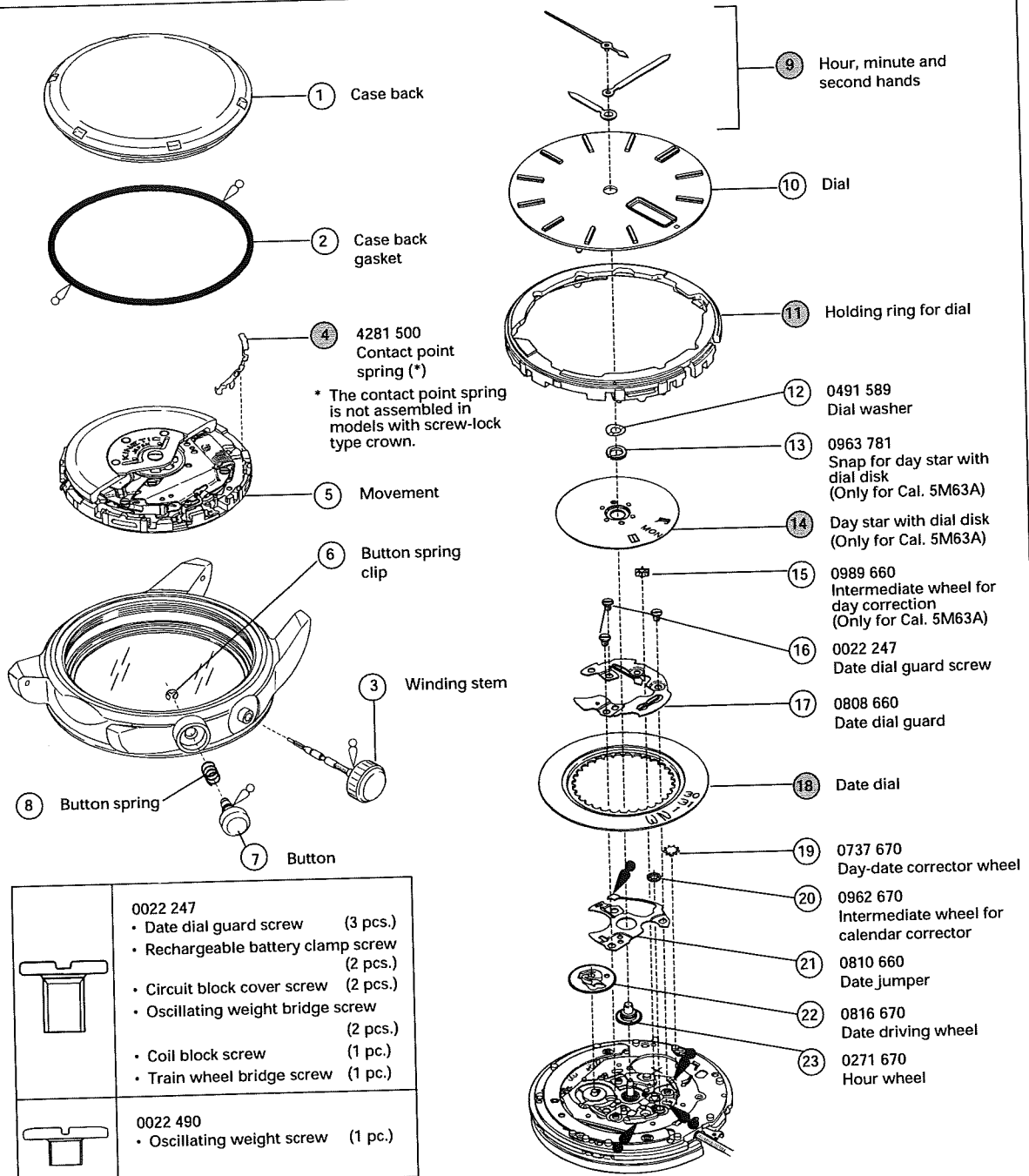

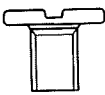
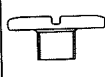
	0022 247	
	• Date dial guard screw	(3 pcs.)
	• Rechargeable battery clamp screw	(2 pcs.)
	• Circuit block cover screw	(2 pcs.)
	• Oscillating weight bridge screw	(2 pcs.)
	• Coil block screw	(1 pc.)
	• Train wheel bridge screw	(1 pc.)
	0022 490	
	• Oscillating weight screw	(1 pc.)

● ➔ Please see the remarks on the following pages.  
 Lubricating of some parts is shown in "II. REMARKS ON DISASSEMBLING AND REASSEMBLING".

# PARTS CATALOGUE

Cal. 5M62A, 5M63A

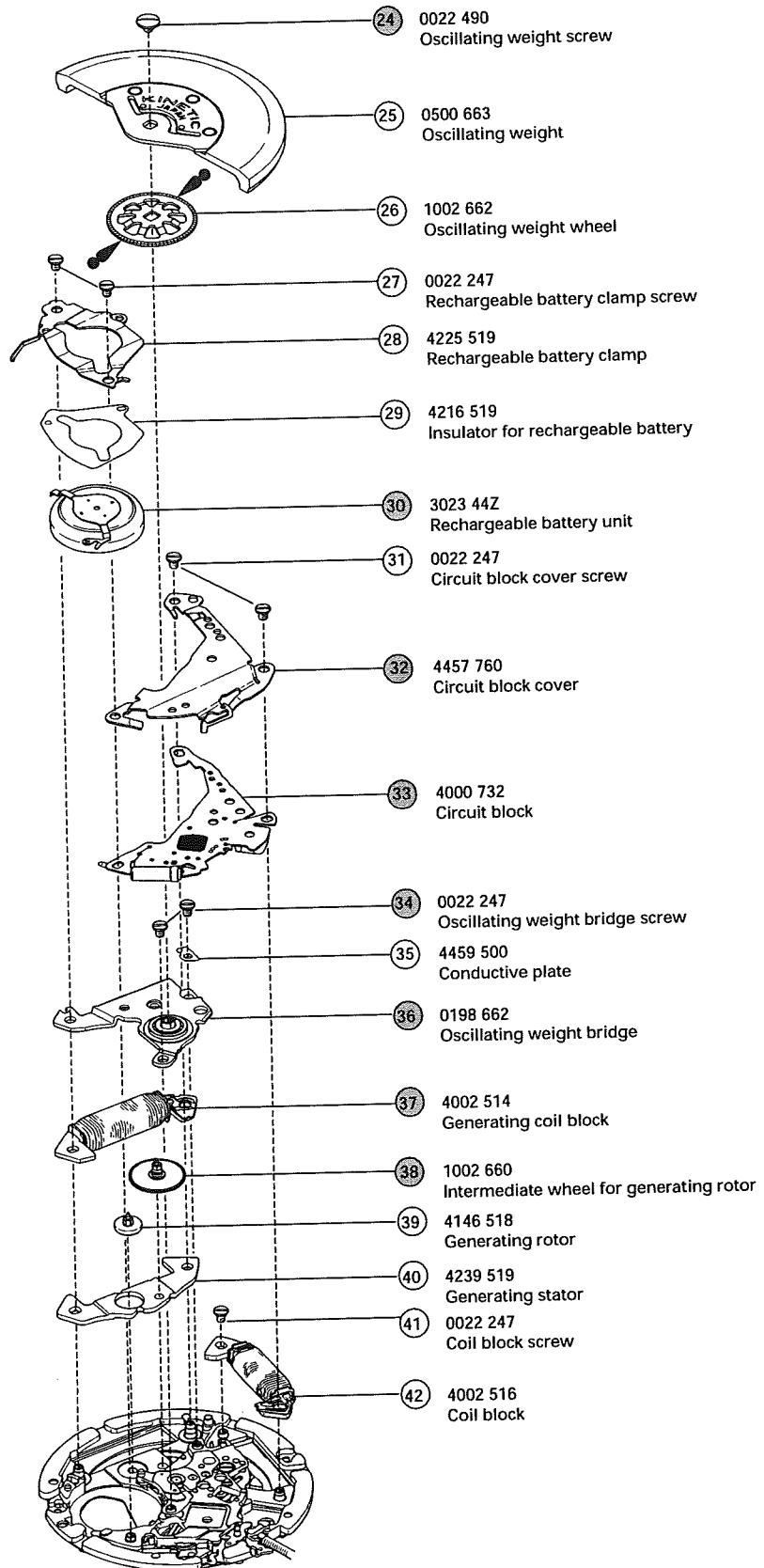

➡ Please see the remarks on the following pages.  
Lubricating of some parts is shown in "II. REMARKS ON DISASSEMBLING AND REASSEMBLING".

# PARTS CATALOGUE

Cal. 5M62A, 5M63A

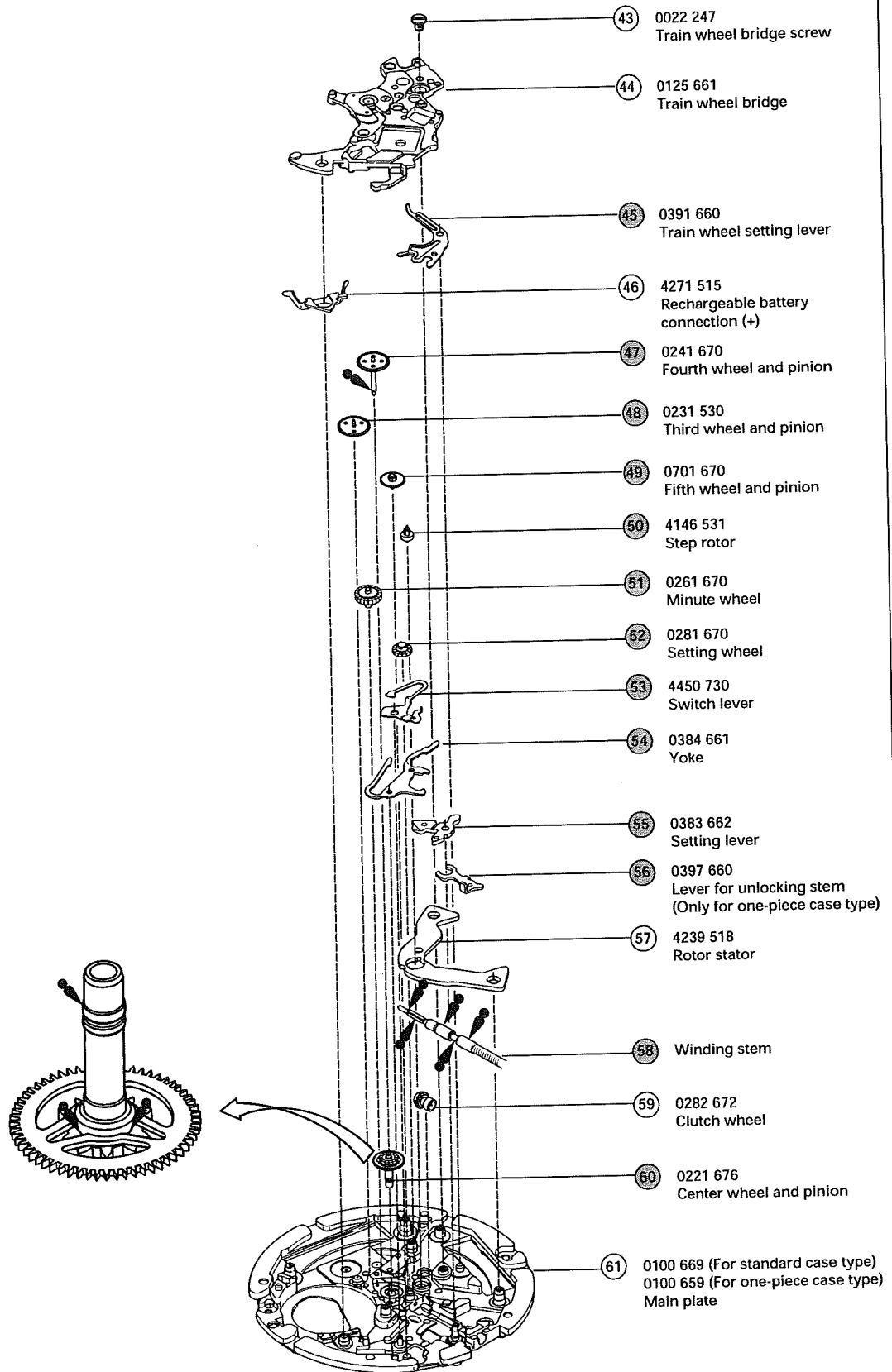

➡ Please see the remarks on the following pages.  
Lubricating of some parts is shown in "II. REMARKS ON DISASSEMBLING AND REASSEMBLING".

# PARTS CATALOGUE

Cal. 5M62A, 5M63A

**Remarks:**

- ④ Contact point spring 4281 500

The contact point spring is not assembled in models with screw-lock type crown.

- ⑪ Holding ring for dial 0866 636

The type of holding ring for dial is determined based on the design of cases.  
Check the case number and refer to "SEIKO Casing Parts Catalogue" to choose a corresponding holding ring for dial.

- ⑭ Day star with dial disk (Only for Cal. 5M63A)

Part code	Language	Position of crown	Position of calendar frame	Color of figure	Color of background
0150 661	English ↔ Spanish	3 o'clock	3 o'clock	Black	White
0150 663	English ↔ Spanish	3 o'clock	3 o'clock	Gold	Black
0150 659	English ↔ Spanish	3 o'clock	3 o'clock	White	Black

The type of day star with dial disk is determined based on the design of cases.  
Check the number printed on the day star with dial disk to choose a corresponding one.

- ⑱ Date dial

Cal. No.	Part code	Position of crown	Position of calendar frame	Color of figure	Color of background
5M62A	0878 729	3 o'clock	3 o'clock	Black	White
	0878 730	3 o'clock	3 o'clock	White	Black
	0878 731	3 o'clock	3 o'clock	Black	Gold
	0878 732	3 o'clock	3 o'clock	Gold	Black
	0878 876	3 o'clock	4 o'clock	Black	White
	0878 877	3 o'clock	4 o'clock	White	Black
5M63A	0878 672	3 o'clock	3 o'clock	White	Black
	0878 673	3 o'clock	3 o'clock	Gold	Black
	0878 675	3 o'clock	3 o'clock	Black	White

The type of date dial is determined based on the design of cases.  
Check the case number and refer to "SEIKO Casing Parts Catalogue" to choose a corresponding date dial.

# PARTS CATALOGUE

Cal. 5M62A, 5M63A

- ⑤⑥ Lever for unlocking stem 0397 660

The lever for unlocking stem is used only with one-piece case type models.

- ⑤⑧ Winding stem 0351 653

The type of winding stem is determined based on the design of cases.  
Check the case number and refer to "SEIKO Casing Parts Catalogue" to choose a corresponding winding stem.

# TECHNICAL GUIDE

Cal. 5M62A, 5M63A

- The explanation here is only for the particular points of Cal. 5M62A and 5M63A.
- For the repairing, checking and measuring procedures, refer to the "TECHNICAL GUIDE, GENERAL INSTRUCTIONS".

## I. STRUCTURE OF THE CIRCUIT BLOCK

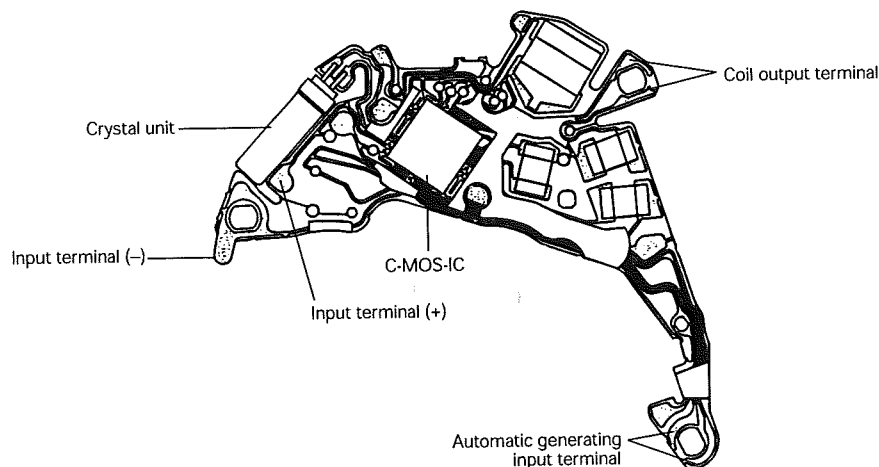

## II. REMARKS ON DISASSEMBLING AND REASSEMBLING

For disassembling and reassembling, be sure to use the universal movement holder.

- ④ Contact point spring

The contact point spring has three hooking portions bent downward. It is fixed by inserting the hooking portion "A" into a gap between the main plate and holding ring for dial and inserting "B" and "C" into a gap between the holding ring for dial and case.

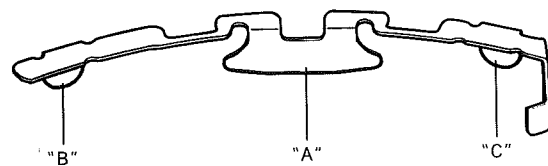

\* Before disassembling or assembling the contact point spring, be sure to remove the winding stem.

# TECHNICAL GUIDE

Cal. 5M62A, 5M63A

## • How to remove

Insert the tip of tweezers into the gaps between the hooking portions "A", "B" and "C" of the contact point spring and holding ring for dial, and pry up the contact point spring slowly to remove it.

## • How to install

- 1) Push the hooking portion "A" in the direction of the arrow in the illustration at right to insert it into a gap between the main plate and holding ring for dial.

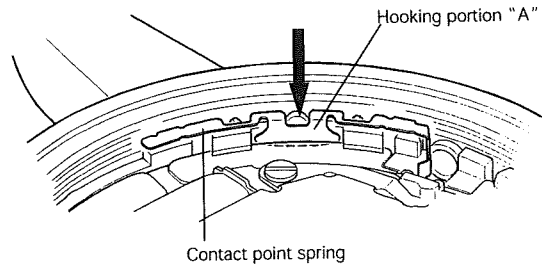

- 2) Insert the hooking portions "B" and "C" into a gap between the holding ring for dial and case. In doing so, the installation will be made more easily by pushing down the contact point spring while slightly lifting it up so that the tips of the hooking portions "B" and "C" are tilted toward the holding ring for dial.

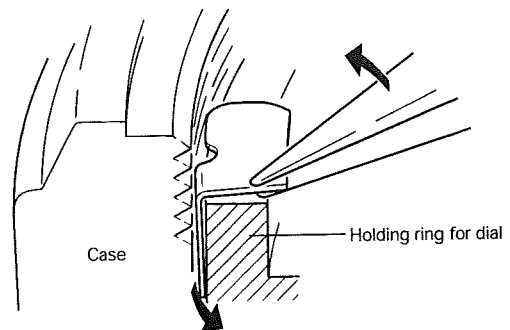

**Note:** When removing or installing the contact point spring, take utmost care not to deform its shape.

## ⑨ Hands

Place the movement directly on the riveting plate shown in the illustration with the oscillating weight down, so that the oscillating weight screw is not damaged. Then, press in the hands.

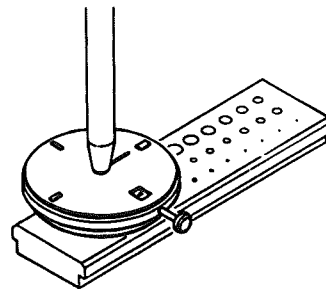
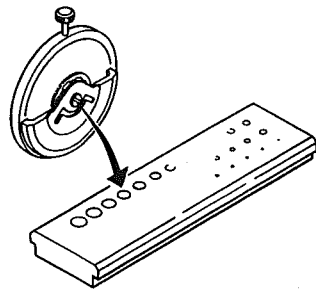

## ⑳ Oscillating weight screw

Tighten the oscillating weight screw firmly, applying more force than usual.

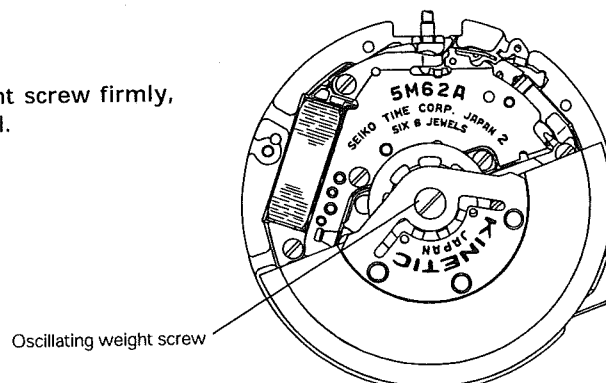





③① Rechargeable battery unit

Though the rechargeable battery unit for Cal. 5M6 Series is of a completely different type from the capacitor unit for Cal. 5M4 Series, they have a close resemblance in shape. They can be discriminated by the shapes of their minus lead terminals as illustrated below. When repairing the rechargeable battery unit, check the shape of its minus lead terminal to make sure you are using a rechargeable battery unit properly.

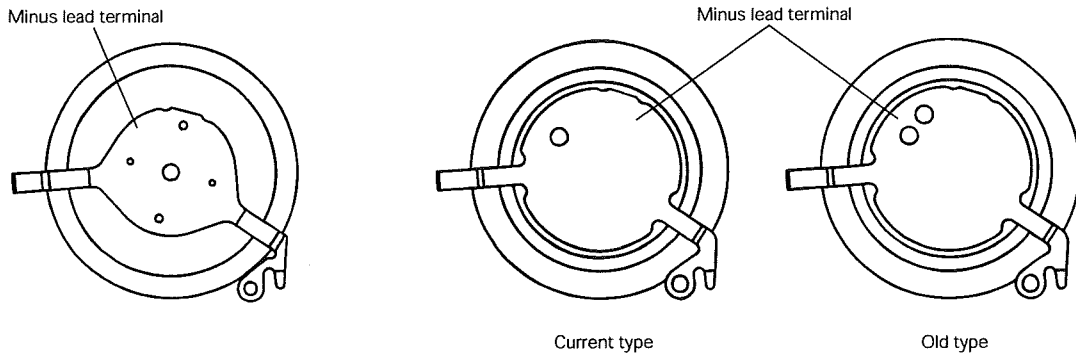

[ Rechargeable battery unit for Cal. 5M6 Series ]

[ Capacitor unit for Cal. 5M4 Series ]

• **How to remove**

Insert the tip of tweezers into the "C" portion gap in the illustration at right, and pry up the rechargeable battery unit to remove it.

• **How to install**

Set the "A" portion of the minus lead terminal to the hole of the main plate, and push the "B" portion down vertically so that the rechargeable battery unit is well seated in position.

**Note:** Take utmost care not to short-circuit the (+) and (-) terminals, as this will deteriorate the battery unit.

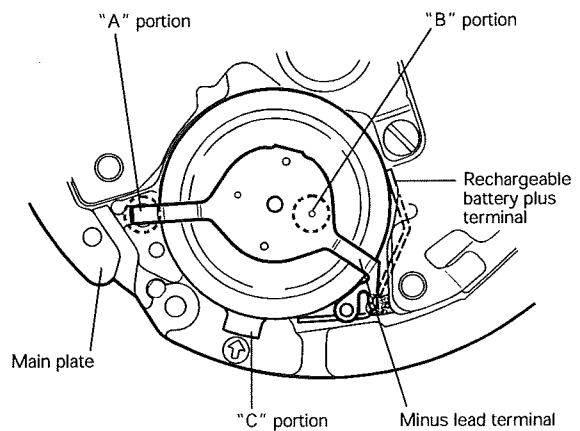

③② Circuit block cover

Circuit block cover for after-sales servicing use has no such marks printed on it as calibre number and numeral indicating hand installation height.

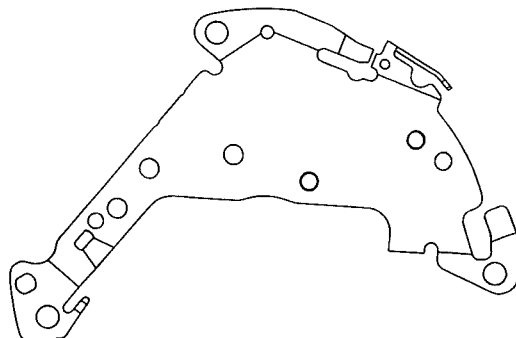

③③ Circuit block

The circuit block for Cal. 5M6 Series and that for Cal. 5M4 Series have a close resemblance in shape. They can be discriminated in the point that the circuit block for Cal. 5M6 Series has no diode element unlike that for Cal. 5M4 Series. When repairing the circuit block, check that it has no diode element to make sure you are using the proper one.

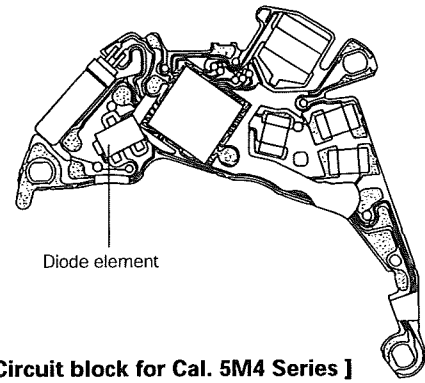
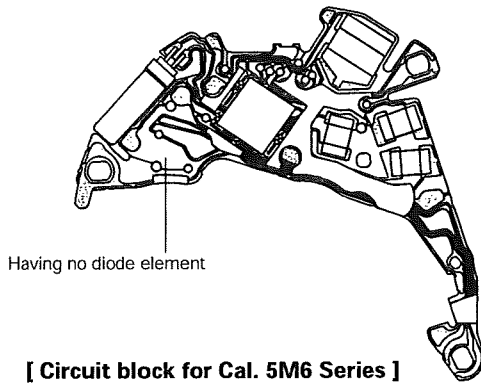

③④ Oscillating weight bridge screw

③⑥ Oscillating weight bridge

- Before tightening the oscillating weight bridge screw, check that the upper pivot of the generating rotor is inserted properly into the pivot jewel.
- Be sure to lubricate the upper and lower pivots of generating rotor and intermediate wheel for generating rotor with the proper oil in the quantity specified in the illustration.

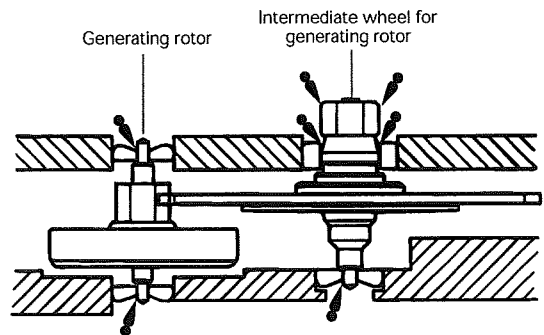

- Lubricate the ball-bearing of the oscillating weight bridge as shown in the illustration at right.

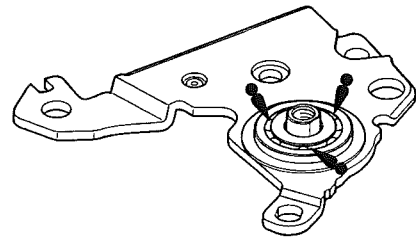

③⑦ Generating coil block

The generating coil block for Cal. 5M6 Series and that for Cal. 5M4 Series have a close resemblance in shape. They can be discriminated by the size of the pattern on the lead terminal. If the generating coil block for Cal. 5M4 Series is assembled by mistake, no electricity will be generated. When repairing the generating coil block, check the size of the pattern on the lead terminal to make sure you are using the proper one.

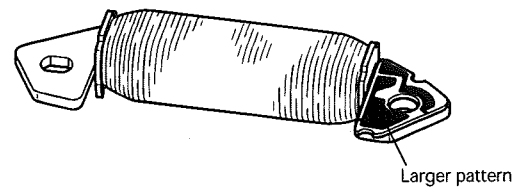
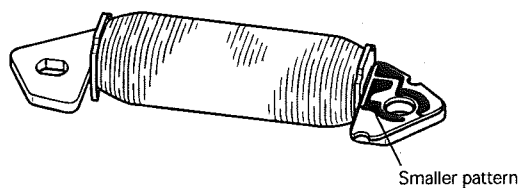

# TECHNICAL GUIDE

Cal. 5M62A, 5M63A

③⑧ Intermediate wheel for generating rotor

• **Lubricating**

Refer to the illustration at right.

**Note:** Be sure to observe the position, type of oil and quantity of the lubrication specified in the illustration.

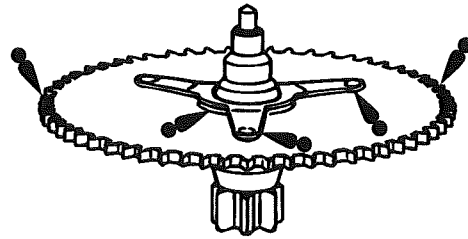

④⑦ Fourth wheel and pinion

④⑧ Third wheel and pinion

④⑨ Fifth wheel and pinion

⑤⑩ Step rotor

⑤① Minute wheel

⑤② Setting wheel

⑥⑩ Center wheel and pinion

• **Setting position and lubricating**

Refer to the illustrations below for the setting position and lubrication of the respective wheels.

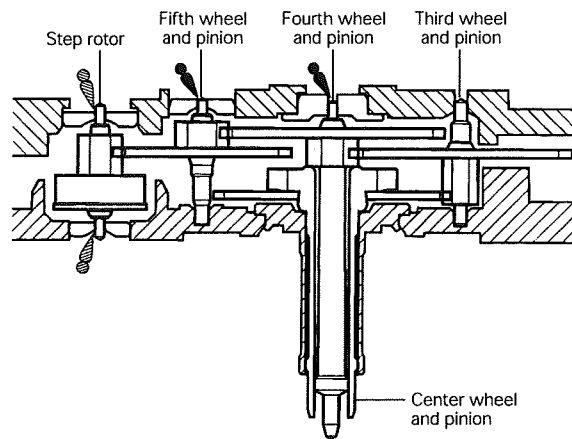
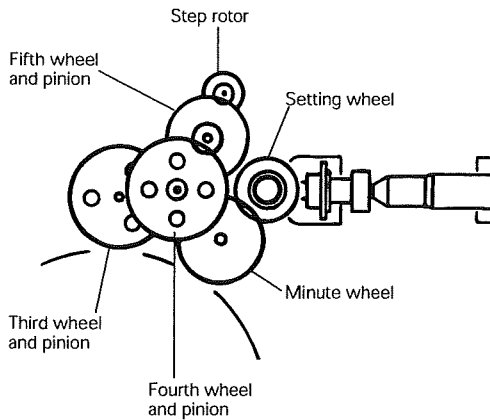

**Note:** Be sure to observe the position, type of oil and quantity of lubrication specified in the illustration.

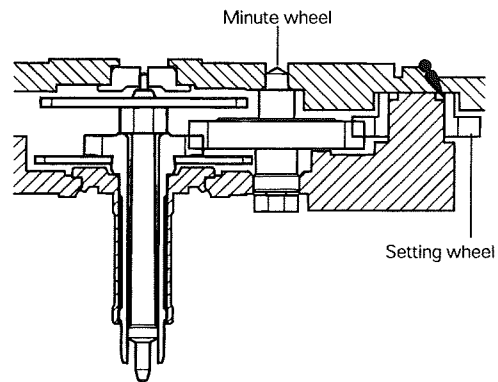

④5 Train wheel setting lever

⑤3 Switch lever

⑤4 Yoke

⑤5 Setting lever

⑤6 Lever for unlocking stem

• **Setting position and lubricating**

Refer to the illustration at right.

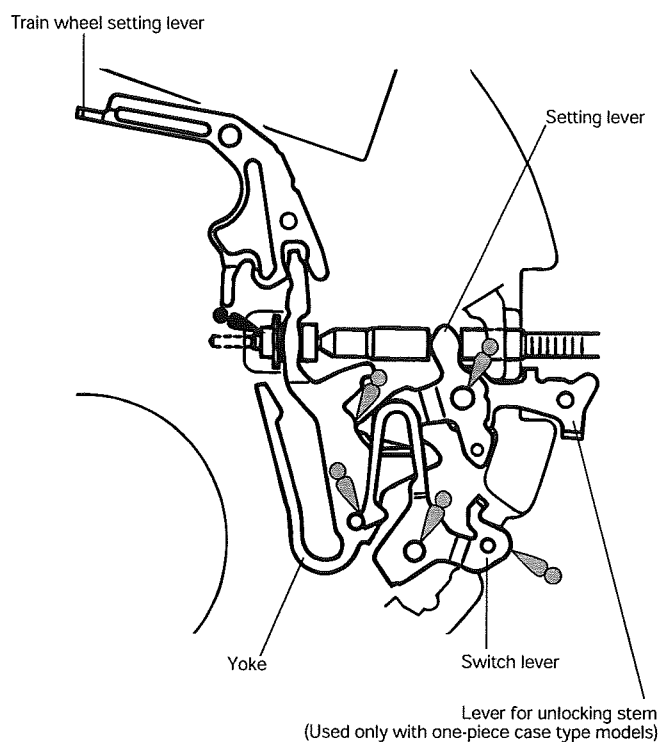

### III. VALUE CHECKING AND ADJUSTMENT

The procedures for value checking and adjustment explained here pertain to both Cal. 5M62A and 5M63A.

● **Coil block resistance**

1.7 K $\Omega$  ~ 2.1 K $\Omega$

● **Generating coil block resistance**

280  $\Omega$  ~ 380  $\Omega$

● **Current consumption**

For the whole movement : Less than 0.80  $\mu$ A (with 1.55 V supplied from a battery)

For the circuit block alone : Less than 0.20  $\mu$ A (with 1.55 V supplied from a battery)

**How to measure the current consumption for the whole movement**

1. Make the movement ready for measurement.
  - 1) Follow the disassembling procedure illustrated in this manual until you remove the rechargeable battery unit.

# TECHNICAL GUIDE

Cal. 5M62A, 5M63A

- 2) Temporarily tighten the screw "A" in the illustration, taking care not to tighten it excessively.
- 3) Install the oscillating weight wheel and oscillating weight and then tighten the oscillating weight screw.

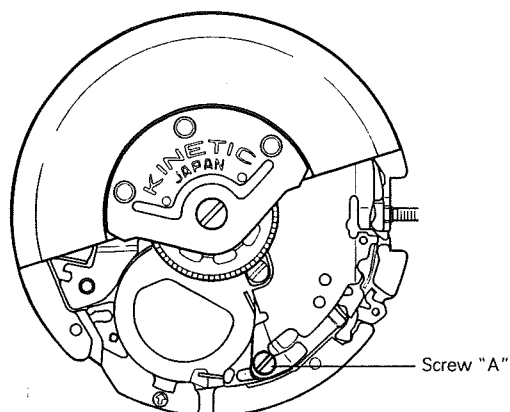

2. Apply the minus terminal to "a" portion of the input terminal (-) in the illustration and plus terminal to the circuit block cover, respectively.

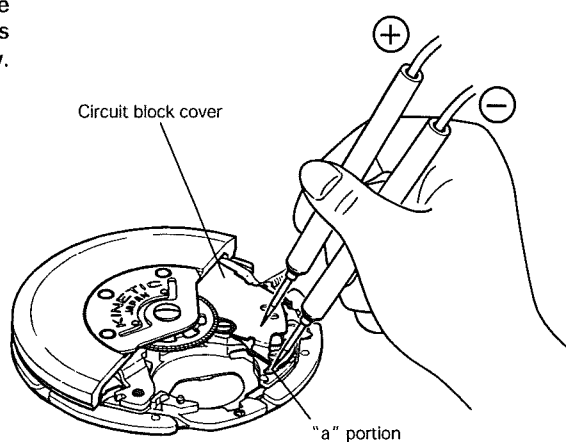

3. For a few seconds after the probes of the tester are applied to the movement, the IC is in the quick start mode, and current consumption cannot be measured properly. To switch the IC from the quick start to the normal hand movement mode, move the oscillating weight from side to side continuously for more than three seconds with the tester connected to the movement. The IC will detect the electricity generation and will be switched to the normal hand movement mode.

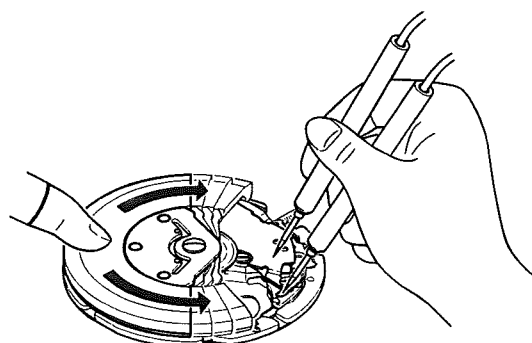

**Note:** When moving the oscillating weight from side to side, take care lest the minus terminal of the tester touches the oscillating weight.

4. After checking that the IC has been switched to the normal hand movement mode and a stable measurement can be obtained, read the measurement. If the measurement value remains high or unstable, repeat step "3" above.

## Notes:

- \* Light may increase the current consumption, resulting in an inaccurate measurement. If the current consumption exceeds the standard value, protect the movement from light with a black cloth or the like, and make a measurement again.
- \* When the current consumption for the whole movement exceeds the standard value while the current consumption for the circuit block alone is within the standard value range, a driving pulse may be generated to compensate for the heavy load applied on the gear train, etc. In that case, overhaul and clean the movement parts, and then, measure the current consumption for the whole movement again.

## How to measure the current consumption for the circuit block alone

1. Connect the tester to the circuit block as shown in the illustration.

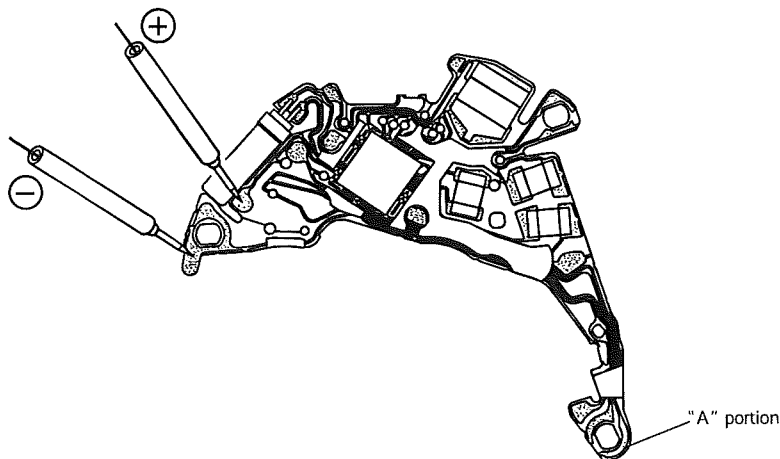

2. With the tester connected to the circuit block, short-circuit "A" portion in the illustration and the input terminal (-) with conductive tweezers or the like for more than 3 seconds. The IC will be switched from the quick start to the normal hand movement mode.
3. Checking that a stable measurement is obtained, read the current consumption. If the measurement value remains high or unstable, repeat step "2" above.

**Note:** The current consumption measurement for the circuit block alone is particularly susceptible to light, and a value higher than the actual measurement may be obtained if the circuit block is exposed to light. Protect the circuit from light with a black cloth or the like after following step "2" above, and then, measure the current consumption.

## ● Checking the automatic generating system

1. Apply the probes of the tester as shown in the illustration, and measure the voltage of the rechargeable battery. The obtained voltage is called the "initial voltage".

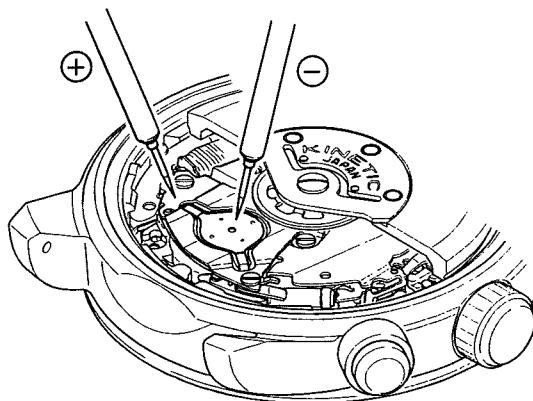

### Notes:

- \* When applying the minus probe of the tester to the rechargeable battery, take care not to short-circuit the lead terminal (-) and the rechargeable battery clamp.
- \* If a short-circuit has occurred, leave the watch untouched for more than 10 minutes, and measure the voltage again, checking that a stable measurement is obtained.

2. Close the case back tentatively, and swing the watch from side to side 200 times at a rate of 2 to 3 swings a second, making an arc of approximately 20 cm.



3. Within 3 minutes after swinging the watch, measure the voltage of the rechargeable battery in the same manner as in step "1" above.
4. If the voltage obtained has increased more than 0.06 V from the initial voltage assuming that the initial voltage is within the range between 0.5 V and 1.0 V, the automatic generating system is operating normally.

**[ For your information ]**

**1. Number of swings and power reserve**

- When the watch stops completely, swinging it approximately 250 times at a rate of 2 to 3 times a second will start the second hand moving at normal one-second intervals instead of two-second intervals, indicating that approximately one day of power has been reserved.  
If the second hand still moves at two-second intervals after 250 swings, swing the watch further until it moves at one-second intervals.
- While the second hand is moving at one-second intervals, 200 to 250 swings will reserve up to one day of power.

**2. Power reserve indication and duration of charge until the watch stops operating**

- Cal. 5M62A and 5M63A are equipped with a power reserve indicator. The current power reserve can be checked using the second hand at the press of the power reserve indicator button.

Quick movement of the second hand when the power reserve indicator function is activated	Duration of charge
5 seconds	Between 1 and 7 days
10 seconds	Between 7 days and 1 month
20 seconds	Approx. 1 month
30 seconds	Between 4 and 6 months

**Note:** Immediately after the watch is charged by swinging it from side to side, the indicator may show power reserve larger than the actual one. In that case, leave the watch untouched for 10 to 15 minutes, and then, check the power reserve.





